

Standards and Specifications of Model: FBD5015B12W3-11-2N

A. General Specification

Item	Specification / Standard / Condition	
Outline Dimension	51 mm x 51 mm x 15 mm	
Bearing	Dual Ball Bearing	
Rated Voltage	DC 12 V	
Operating Voltage	DC 7.00 V ~ DC 13.20 V	
Starting Voltage	DC 7.00 V	1. Rated Voltage 2. 25°C, 65% RH
Rated Current	0.08 A	
Power Consumption	0.96 W	
Speed	4,500 R.P.M.	1. Free Air 2. Rated Voltage 3. 25°C, 65% RH 4. Tolerance: ± 10%
Maximum Airflow	3.40 CFM	1. Rated Voltage 2. AMCA Standard 3. Rated Current
Maximum Static Pressure	9.20 mm-H ₂ O	
Noise Level	35.40 dB (A)	1. Rated Voltage 2. Measured in a Non-Echo Chamber 3. CNS 8753 Standard 4. ISO 3744 Test Condition
Life	80,000 hrs	40°C, L10 at Conf. Level 90%, Rated Voltage
Net Weight	28 g	
Number of Pole	4 Poles	
Rotating Direction	Counter-Clockwise	
Plastic Material: Blade, Housing, Bobbin	1. UL 94V-0 2. P.B.T. + 30% GF Black	
Lead Wire	UL 1007, 26 AWG	Red: (+) Black: (-)
Connector		

B. Electrical Specification

Item	Specification / Condition
Locked Rotor Protection	No damage done for a continuous 72 hours rotation lock at rated voltage.
Polarity Protection	Circuit is protected when V _{CC} & GND are exchanged.
Insulation Resistance	10 m. Ohm / between unshielded wire and frame at 500 VDC/min.
Dielectric Strength	5 mA Maximum. / Measured between lead wire + and frame at 500 VAC/min.

C. Environmental Specification

Item	Specification / Condition
Operating Condition	Temperature: -20°C ~ + 70°C Humidity: 15% ~ 90% RH
Storage Temperature	Temperature: -40°C ~ + 85°C Humidity: 15% ~ 90% RH
Humidity	Per MIL-STD-202F Method 103B Life: 96 hours Temperature: +40 ± 2°C
Thermal Shock	Per MIL-STD-202F Method 107D, Condition D
Packing Vibration Test	Packing condition: X, Y, Z 3 directions, 1.1G load vibration test for 30 min.
Packing Shock Proof Test	1 corner, 3 edges, 6 faces natural drop from 60cm high, packed

D. Safety Approvals



Safety Approval	File No.
UL	E194726
CUL	E194726
TUV	R50048194

E. Label Marking

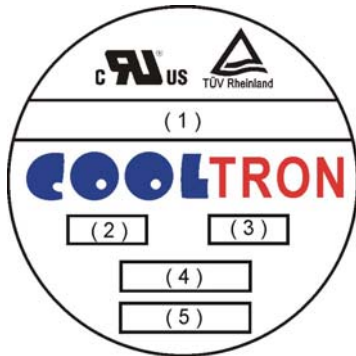

(1)	Model Number
(2)	Rated Voltage
(3)	Power Consumption
(4)	Bearing Type
(5)	Location

F. Air Flow Performance Curve

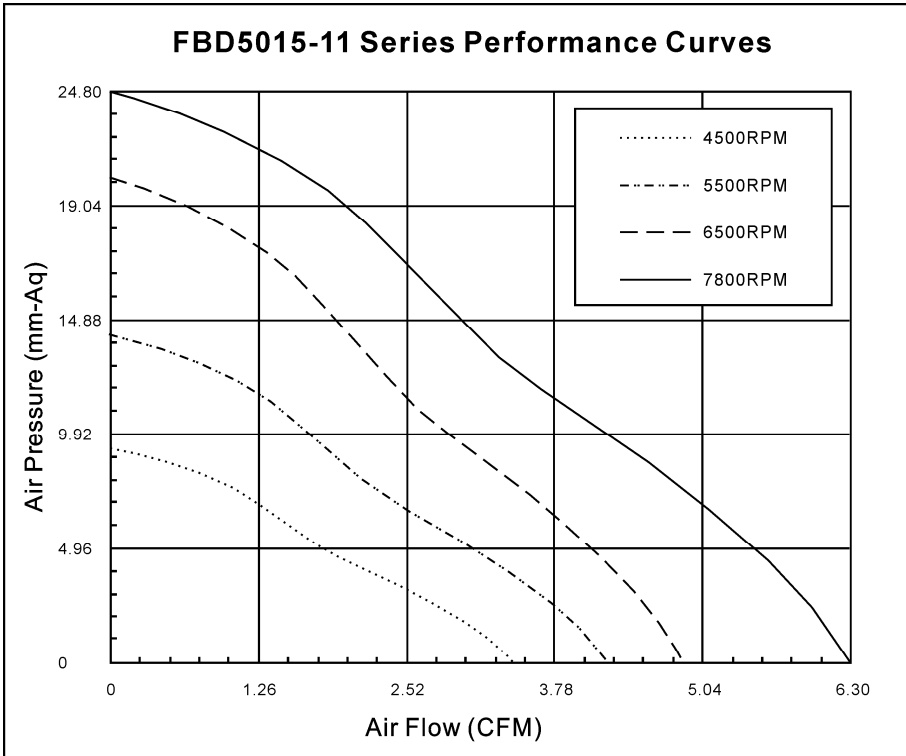

G. Model Drawing

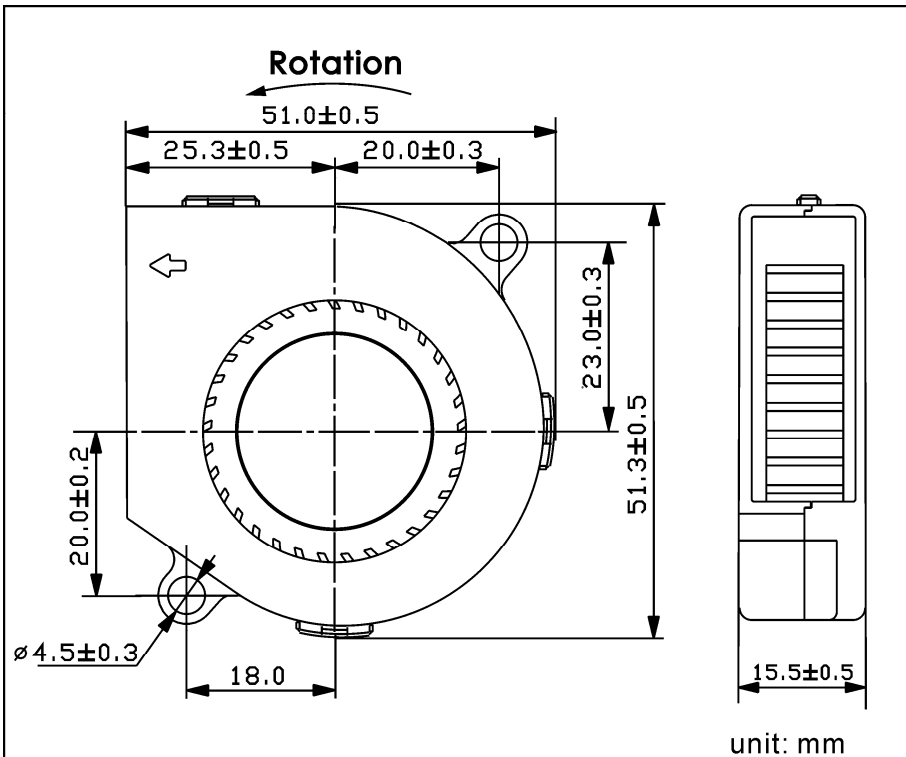

H. Fan Photos



FBD5015-11