

DC AXIAL FAN 80x80x25mm



Housing/Blade: Thermoplastic PBT, UL 94V-0
 Insulation Resistance: 10MΩ, 500VDC/min between bare wire and frame
 Dielectric Strength: 5mA max. 500VAC/min between bare wire and frame
 Operation Temperature: -10°C~70°C(Humidity 5%~90%RH)
 Storage Temperature: -40°C~80°C(Humidity 5%~95%RH)
 Lead Wire: UL Type #24 AWG
 Weight: 80 g Packing: 100PCS/CTN



Model Number	Voltage (VDC)	Op.Voltage (VDC)	Air Flow (CFM)	Static Pres. (mm-H ₂ O)	Noise (dBA)	Speed (RPM)	Current (mA)	Power (W)	Available Bearing	Curves
FD8025B05W9-87	★▲ 5	3.0~5.5	35.10	3.20	24.80	2,700	260	1.30	B/L/S	①
FD8025B12W1-87A	★▲ 12	6.0~13.2	35.10	3.20	24.80	2,700	100	1.20	B/L/S	①
FD8025B12W3-87D	★▲ 12	6.0~13.2	39.10	3.90	27.70	3,000	170	2.04	B/L/S	②
FD8025B12W5-87	★▲ 12	6.0~13.2	48.20	5.40	31.60	3,600	230	2.76	B/L/S	③
FD8025B12W7-87D	★▲ 12	6.0~13.2	57.60	7.40	37.30	4,300	410	4.92	B/L/S	④
FD8025B12W9-87	★▲ 12	6.0~13.2	66.50	9.80	41.30	5,000	550	6.60	B/L/S	⑤
FD8025B12W11-87	★▲ 12	6.0~13.2	75.70	12.60	44.60	5,700	630	7.56	B/L/S	⑥
FD8025B24W1-87D	★▲ 24	12.0~26.4	35.10	3.20	24.80	2,700	40	0.96	B/L/S	①
FD8025B24W3-87D	★▲ 24	12.0~26.4	39.10	3.90	27.70	3,000	90	2.16	B/L/S	②
FD8025B24W5-87	★▲ 24	12.0~26.4	48.20	5.40	31.60	3,600	140	3.36	B/L/S	③
FD8025B24W7-87	★▲ 24	12.0~26.4	57.60	7.40	37.30	4,300	210	5.04	B/L/S	④
FD8025B24W9-87	★▲ 24	12.0~26.4	66.50	9.80	41.30	5,000	250	6.00	B	⑤
FD8025B48W5-87D	★▲ 48	24.0~52.8	39.10	3.90	27.70	3,000	60	2.88	B/L/S	②
FD8025B48W7-87D	★▲ 48	24.0~52.8	48.20	5.40	31.60	3,600	90	4.32	B/L/S	③
FD8025B48W9-87D	★▲ 48	24.0~52.8	57.60	7.40	37.30	4,300	140	6.72	B/L/S	④
FD8025B48W11-87D	★▲ 48	24.0~52.8	66.50	9.80	41.30	5,000	210	10.08	B	⑤

- If model depicts "★", auto restart protection function built in.
- If model depicts "▲", polarity protection function built in.

Specifications are subject to change without notice

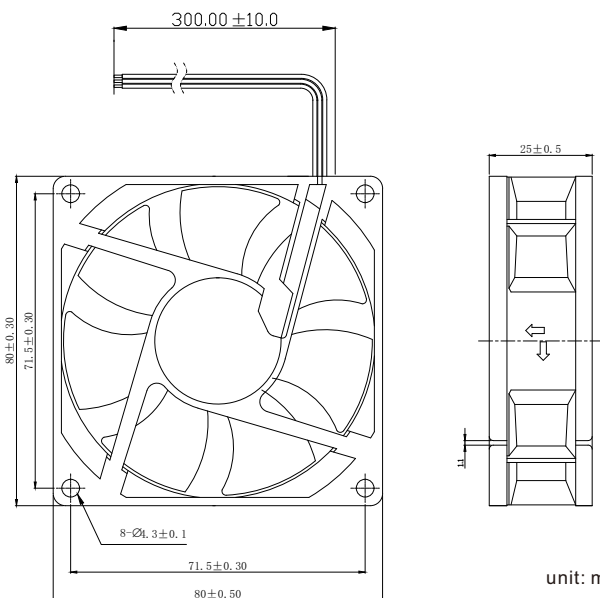

unit: mm

