



PRODUCT SPECIFICATION SHEET

CUSTOMER: _____

CUSTOMER MODEL NO.: _____

COOLTRON MODEL NO.: FD4010B12W5-71-2N

DESCRIPTION: DC Fan, 40x40x10mm, 12VDC,
5400RPM, Dual Ball Bearing
No Connector.

EDITION: A00

ISSUE DATE: 11/16/2023

Products will meet the specifications stated on this data sheet for all future production orders unless a revision has been approved by both parties.

Industrial Supply, Inc.

19929 Harrison Ave., Industry, CA 91789 Tel: 909-598-6033 Fax: 909-598-6043 www.cooltron.com

Standards and Specifications of Model: FD4010B12W5-71-2N



A. General Specification

| Item | | Specification / Standard / Condition | |
|------|-------------------------------------|--|-----------------------|
| 01 | Outline Dimension | 40 x 40 x 10 | mm |
| 02 | Bearing | Dual Ball Bearing | |
| 03 | Rated Voltage | DC 12 | V |
| 04 | Operating Voltage | DC 10.8 | V ~ DC 13.2 V |
| 05 | Starting Voltage | DC 10.8 | V |
| 06 | Rated Current (Max.) | 0.06 | A |
| 07 | Actual Current | 0.06 | A |
| 08 | Power Consumption | 0.72 | W |
| 09 | Rated Speed | 5,400 | R.P.M. ± 15% |
| 10 | Maximum Airflow | 5.70 | CFM |
| 11 | Maximum Static Pressure | 2.50 | mm-H ₂ O |
| 12 | Noise Level | 24.50 | dB (A) |
| 13 | Life Expectancy | 70,000 | Hrs. at 40°C |
| 14 | Net Weight | 13 | Gram |
| 15 | Number of Blade | 9 | Blades |
| 16 | Number of Pole | 4 | Poles |
| 17 | Rotating Direction | Counter-Clockwise | Looking at Rotor Side |
| 18 | Plastic Material: Housing, Blade | Housing: Plastic UL 94V-0 P.B.T. Blade: Plastic UL 94V-0 P.B.T. | |
| 19 | Lead Wire | UL Type #26 AWG | Red: (+) Black: (-) |
| 20 | Connector | Without | |
| 21 | Special Function | Without | |

B. Electrical Specification

| Item | | Specification / Condition | |
|------|-------------------------|---------------------------|---|
| 01 | Locked Rotor Protection | ✓ | Safety Condition |
| | | ✗ | a. Auto power off after locked at rated voltage for 1 sec. b. After auto power off, circuit attempt to restart in 2-6 sec. |
| 02 | Polarity Protection | ✗ | a. Circuit is protected when VCC & GND are exchanged, b. The circuit won't be burned within 5 seconds. |
| 03 | Insulation Resistance | ✓ | 10 m.Ohm / between unshielded wire and frame at 500 VDC/min. |
| 04 | Dielectric Strength | ✓ | 5 mA Maximum. / Measured between lead wire (+) and frame at 500 VAC/min. |

C. Environmental Specification

| Item | | Specification / Condition |
|------|--------------------------------|---|
| 01 | Operating Condition | Temperature: -10°C ~ + 70°C Humidity: 35% ~ 85% RH |
| 02 | Storage Temperature | Temperature: -40°C ~ + 70°C Humidity: 35% ~ 85% RH |
| 03 | Test of high & low Temperature | Test Circulation at -10°C & 70°C two times per 4 hours |
| 04 | Packing Vibration Test | Packing condition: X, Y, Z 3 directions, 1.1G load vibration test for 30 min. |
| 05 | Packing Shock Proof Test | 1 corner, 3 edges, 6 faces natural drop from 60cm high, packed |

D. Safety Approvals



| Safety Approval | File No. |
|-----------------|---------------|
| CE | TB10088262 |
| UL | E194726 |
| CUL | E194726 |
| TUV | B 11 07 57907 |

E. Label Marking

01: Fan Label Marking

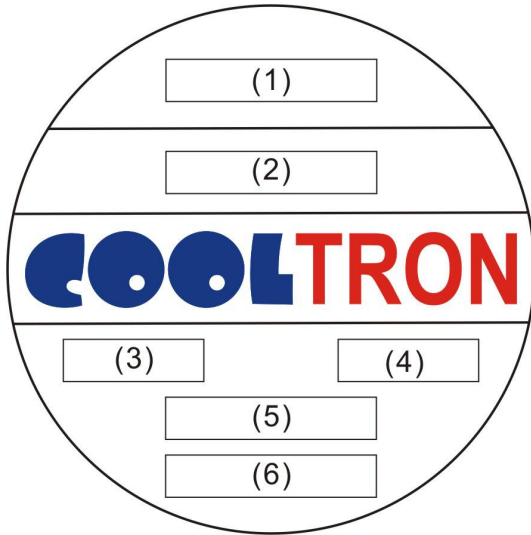

| | |
|-----|------------------------------|
| (1) | Safety Approval |
| (2) | Model Number & Appendix Code |
| (3) | Rated Voltage |
| (4) | Power Consumption |
| (5) | Bearing Type |
| (6) | Location |

02: RoHS Label Marking:



| Label | Location |
|------------------|------------------|
| RoHS & Date Code | Fan Outlet Frame |

F. Air Flow Performance Curve

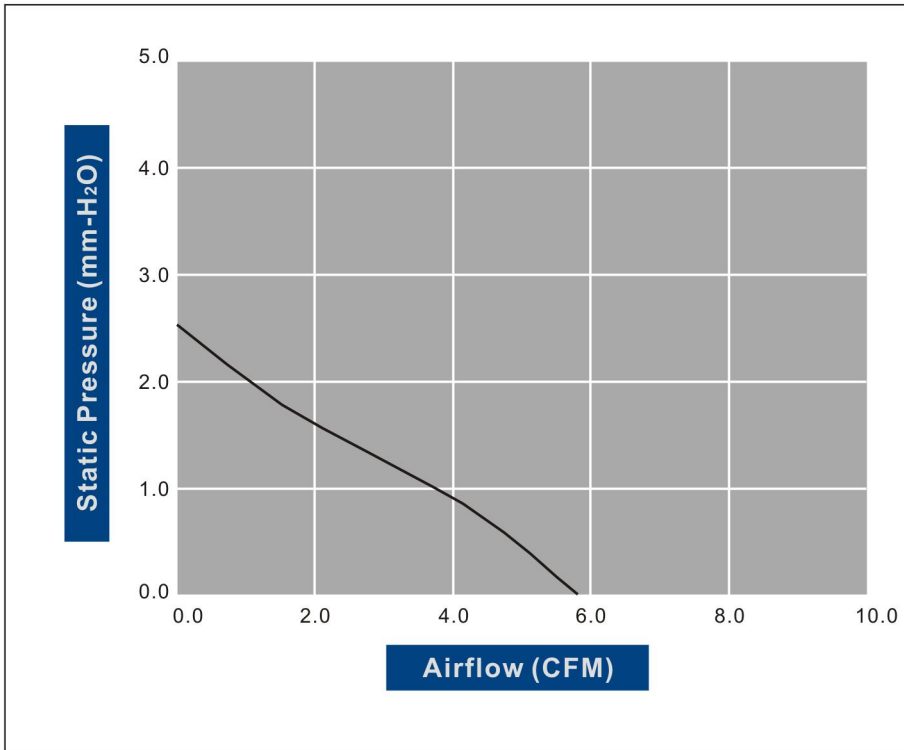

G. Model Drawing

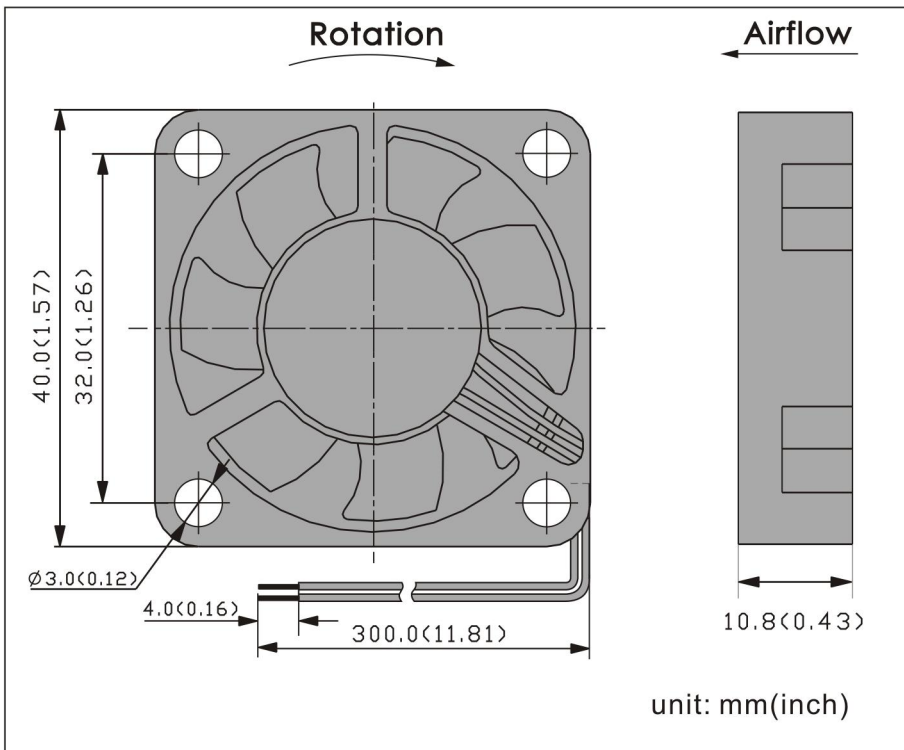

H. Fan Photos

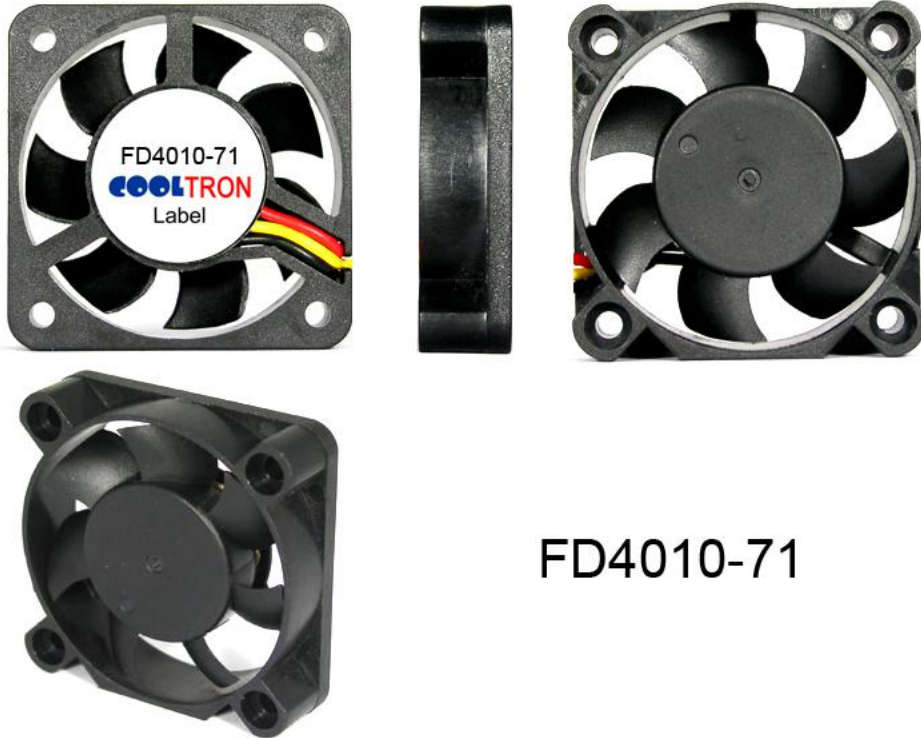

FD4010-71

REMARKS

1. COOLTRON will not assume responsibility for the performance of the products if the application conditions fall outside the parameters stated forth in this specification.
2. A written request should be submitted to COOLTRON prior to approval if abnormality and deviation from this specification is required.
3. Please be cautious when fan is being exercised or handled. Damages may be resulted when apply pressure to the impeller or hold the fan by the lead wires or drop the fans to the production platform.
4. With exception of suitability of some particular designs, any failure and problems regarding safety of the product caused by the introduction of powder, droplets of water or encroachment of insert in the hub are not guaranteed.
5. All general specifications and quality values are measured under condition of free air and fan vertical set up. COOLTRON highly suggests practicing a test when fan apply to a special application.
6. COOLTRON fans are not suitable to be used in an environment that contains aggressive or corrosive fluids.
7. Always ensure that fans are stored according to the storage temperatures specified. Do not store in an environment with a high humidity level. If the fans were stored for longer than 6 months, it is highly recommended to apply functional testing before shipping.
8. Except for the feature of the Lock Rotor Protection specifically stated, this feature is not applied to all fans. COOLTRON highly suggests not to stop the impellers of the working fans such interruption will cause adverse effect.
9. During installation, please be cautious. COOLTRON is not responsible for any excess resonance, vibration and subsequent noise caused by incorrect mounting of fans.
10. During testing it is important to consider safety at all times. A suitable guard should be fitted to the fan to prevent personal injury.
11. All test environments are conducted under the condition of relative (ambient) temperature and humidity at 25°C, 65%RH. The test result stated above is effective only for unique fan performance.
12. The above conditions are examples of extreme application. However they are very important and should receive top priority.